

G.R.I.D. PROJECT
MEATCHUNK ENTERPRISES, INC ©
SPRING 2014
booklet version 02

G.R.I.D. PROJECT

Gridded
Repeatable
Integrated
Design

MODULAR ARTWORKS

BACKGROUND INFORMATION

"BODY" COMPONENTS IN STACKS AFTER DE-INSTALL >



Sixty 23 inch square panels from "body" stacked after dis-assembly of structure. The piece started as a 8 foot tall by 30 foot long wall (approximate) that bisected the gallery space. Over the course of the 3 week long show, a drawing was made using enamel paint markers with the primary colors. One color with black and white was used per week and an improvised drawing was executed while security cameras recorded the work in progress. After dis-assembly, each panel was then worked individually for the next show, which took place at another location a month later.

"MIND/BODY/SOUL" COMPONENTS INSTALLATION 2005 >

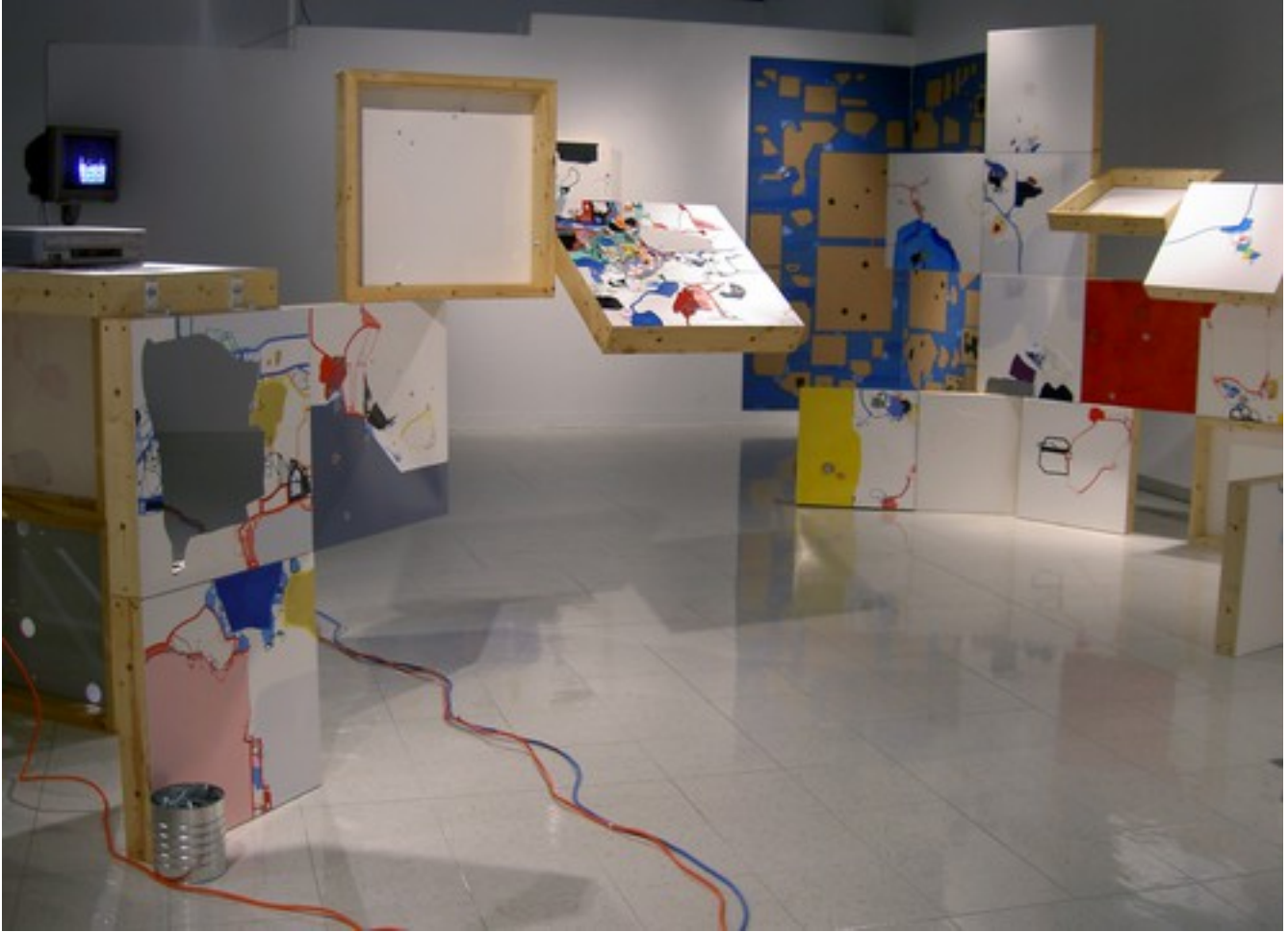

Installation of panels in "permutations" graduate thesis show at Ohio University. The "paintings" are bolted together to create more sculptural forms throughout the gallery space. Evidence of the process exists in the installation with exposed containers of bolts and tracings of parts on cardboard wall diagrams. Custom made brackets were fabricated to make the panels work together to become freestanding sculptures. Components from two separate works "mind" and "body" were put together to make "new" works in this exhibition and were disassembled after show closed. The individual panels were worked on separately again for another installation at Majestic Galleries a year later.

"MIND/BODY/SOUL" COMPONENTS INSTALLATION 2006 >



Panels from "mind" and "body" in art installation "the path: the journey" at Majestic Galleries in 2006. An IMac mounted in one wall piece played a looping Power Point slide show of documentation of previous art installations "mind/body/soul" and "permutations". The presentation showed panels arranged differently and in earlier states and gave context to the possibilities of further growth and manipulation. Components of the panels were removed and mounted to the wall with drawings to give a feeling of motion and continuous change.

"BODY" COMPONENTS INSTALLATION 2006 >



Nine 23 inch square panels bolted together for art installation "the path: the journey" in spring 2006. Each panel is a section of "body" from 2005 installation "mind/body/soul" that has been individually worked and then assembled into this state. These works have since been disassembled and used for other projects and /or been reworked.

**RIGHT TRIANGLE GRID UNIT (RTGU)
SKETCHES**

SKETCH FOR MODULAR UNIT SIZE >

MODULAR UNITS

$$a^2 + b^2 = c^2$$

1 UNIT = 1 FOOT ^{ONE} X 1 FOOT TRIANGLE

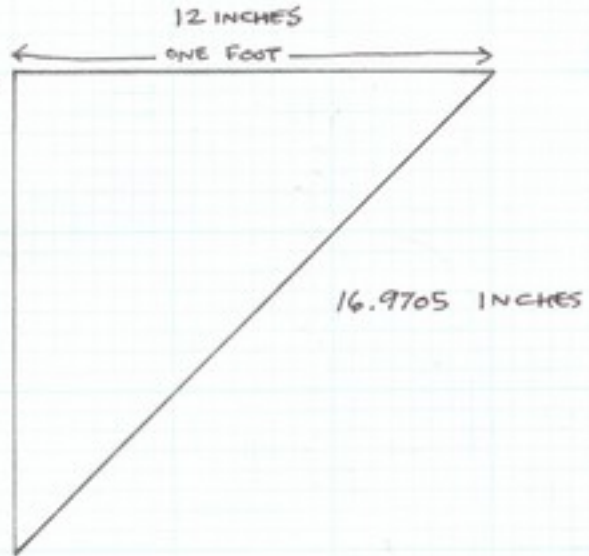

1 QUADRANT ~~SECTION~~ = FOUR UNITS

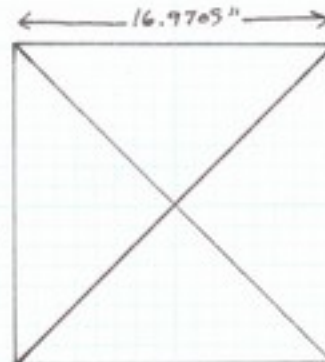

1 DUO = TWO UNITS

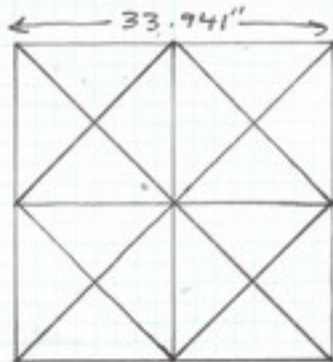
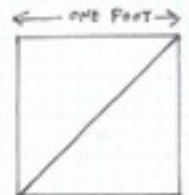

16 UNITS

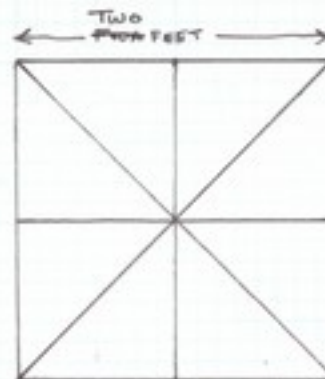

8 UNITS



SKETCH SHOWING MOUNTING HOLE PLACEMENT >

MODULAR UNIT FRAMEWORK

5.6567

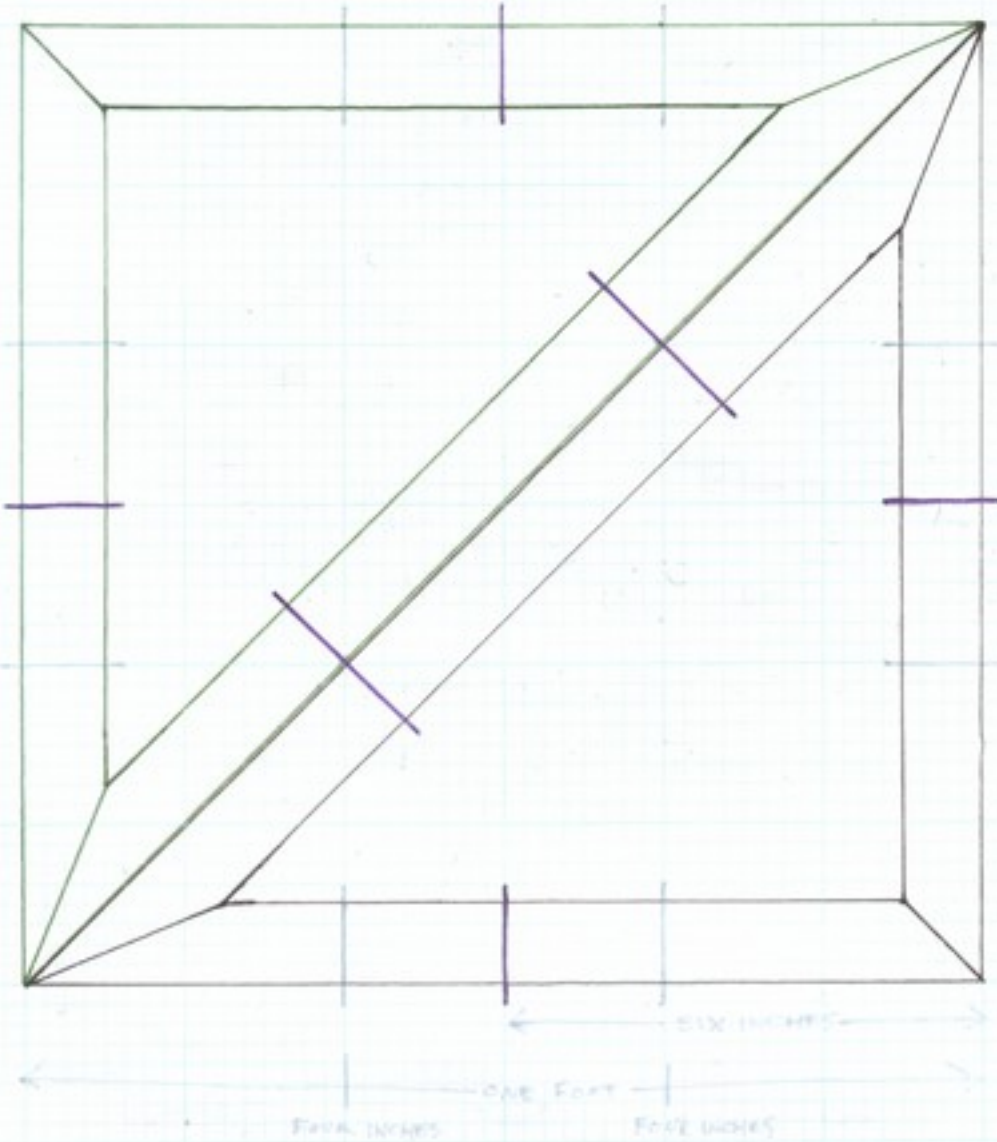

SCALE DRAWING SHOWING THREE UNITS >

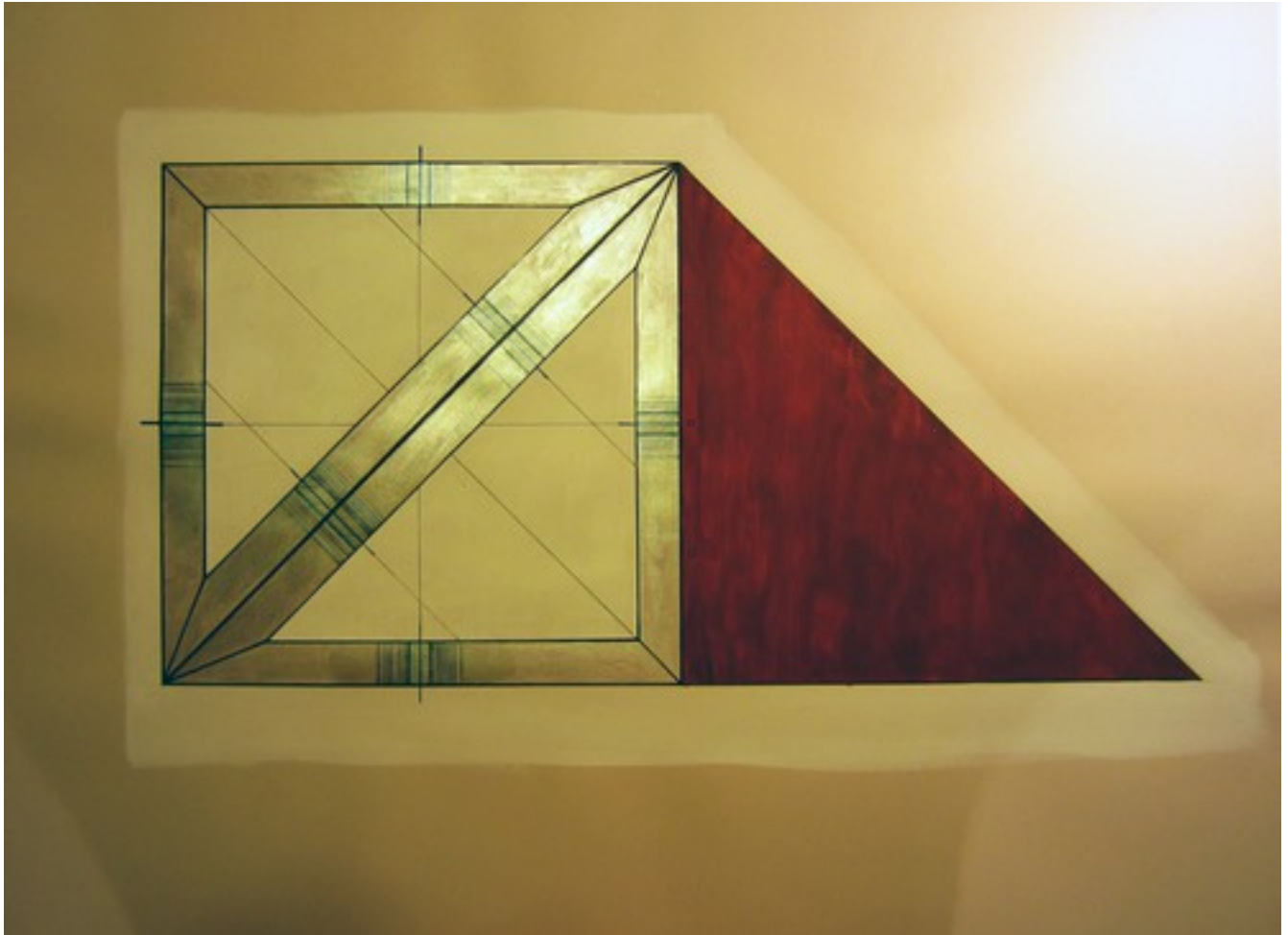

**RIGHT TRIANGLE GRID UNIT (RTGU)
PROTOTYPE (WOOD FRAME, MDF BACKING)**

FRONT FACE WITH 1MM SINTRA® SKIN >

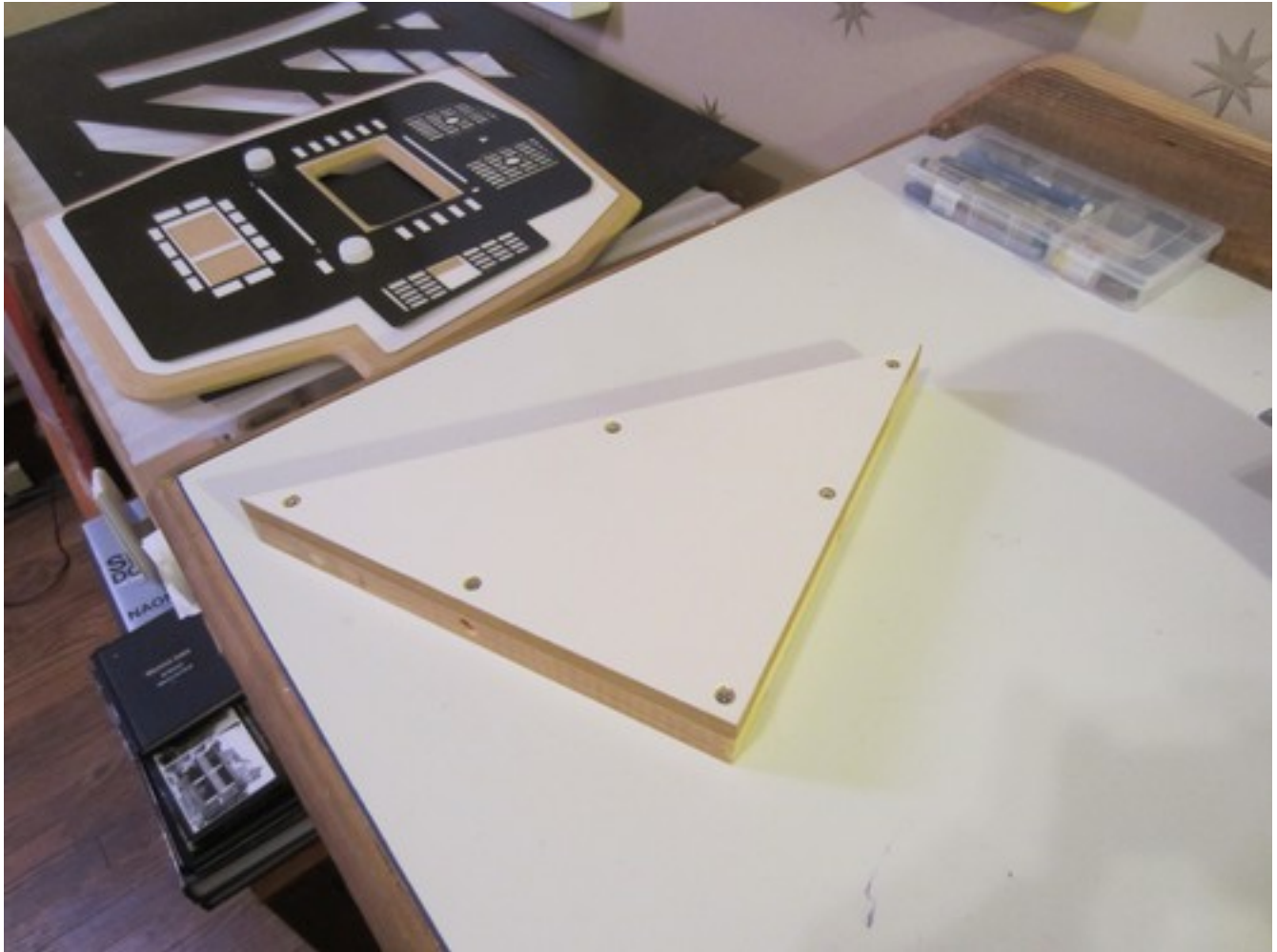

BACK WITH 1 INCH SQUARE WOOD FRAME AND $\frac{1}{2}$ MDF >
BACKING



SCREW ACCESS FOR EASY DISASSEMBLY >



**COMPUTER MODELS FOR
RTGU ASSEMBLY**

TWO UNITS = DUO >
12 INCHES SQUARE

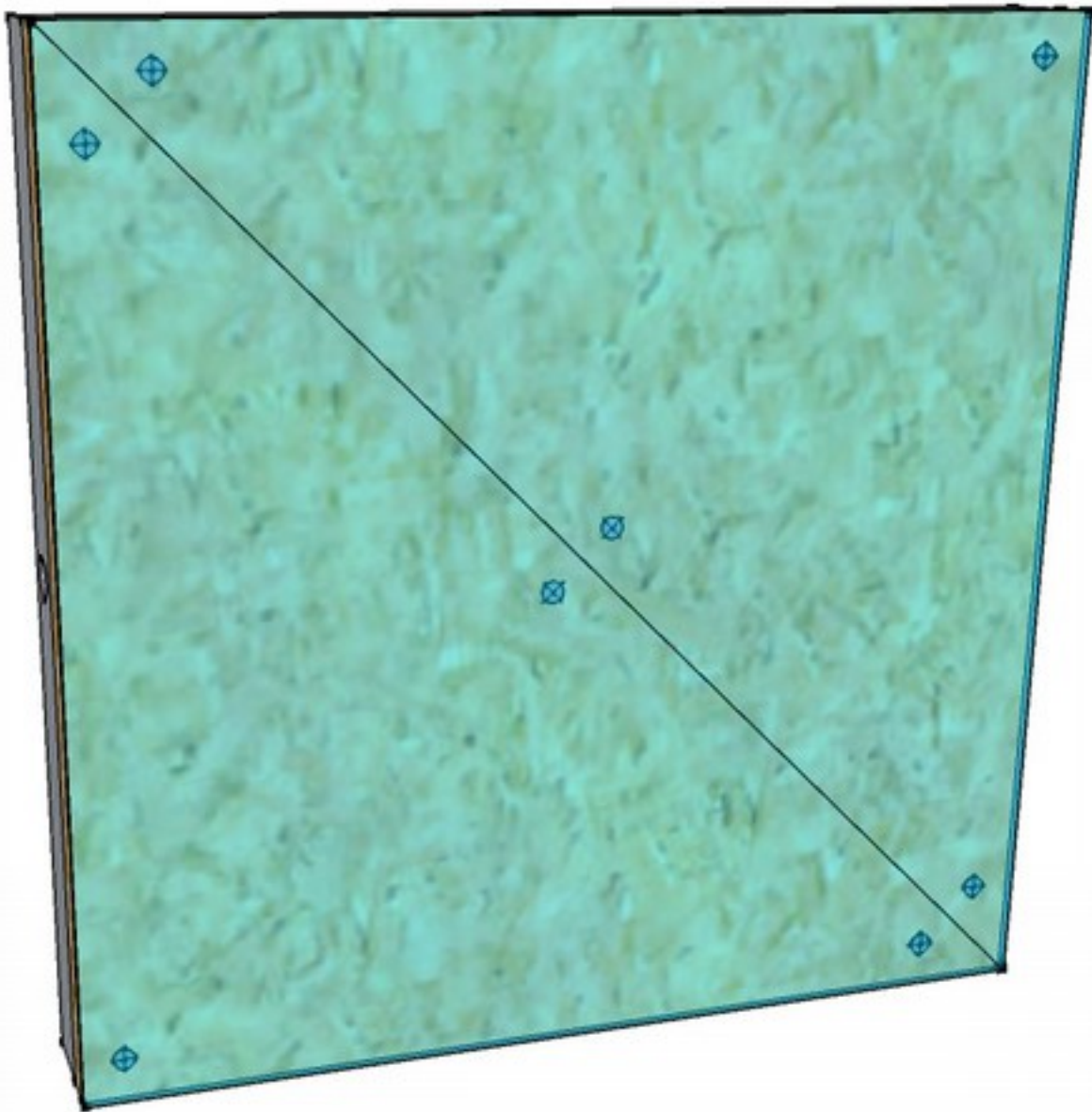

8 UNIT FRAMEWORK-24 INCH SQUARE >
(ALUMINUM FRAME ONLY)

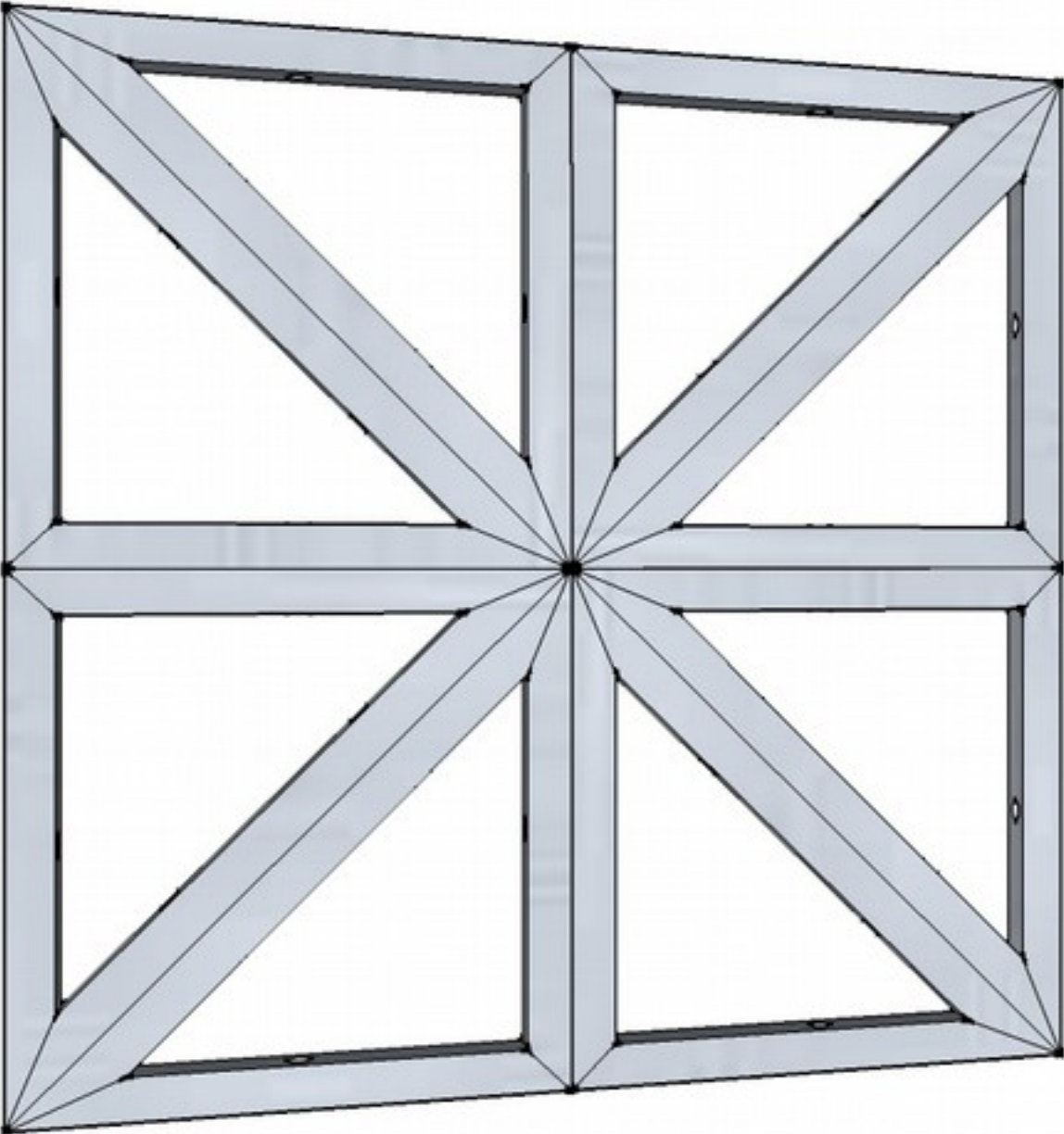

DUO-12 INCH SQUARE (RIGHT) >
8 UNIT-24 INCH SQUARE (LEFT)

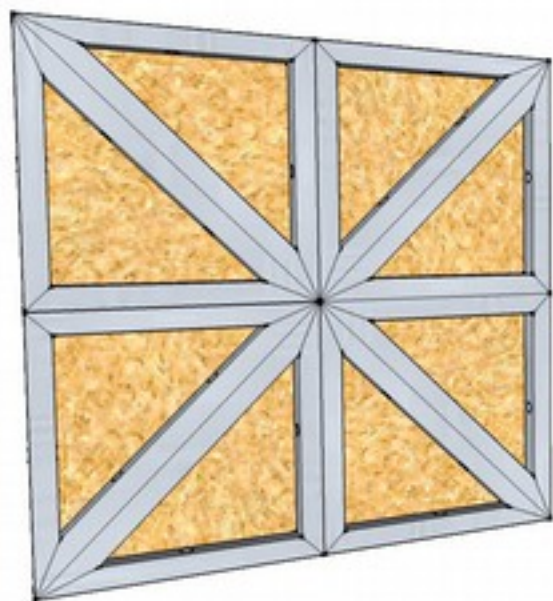

16 UNIT SQUARE-APPROX. 34 INCH SQUARE >

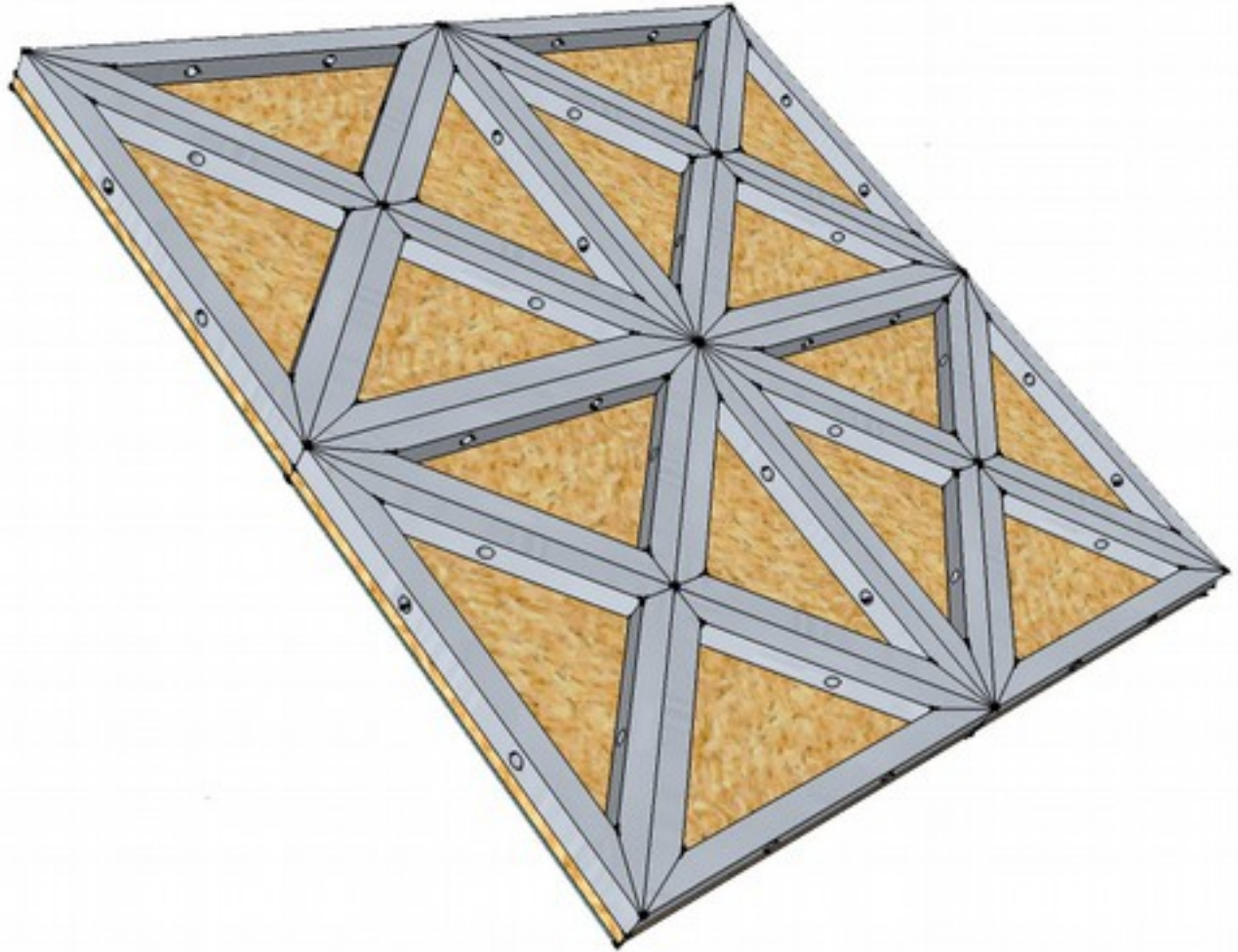

8 FOOT SQUARE WITH WALL MOUNTING BRACKET >

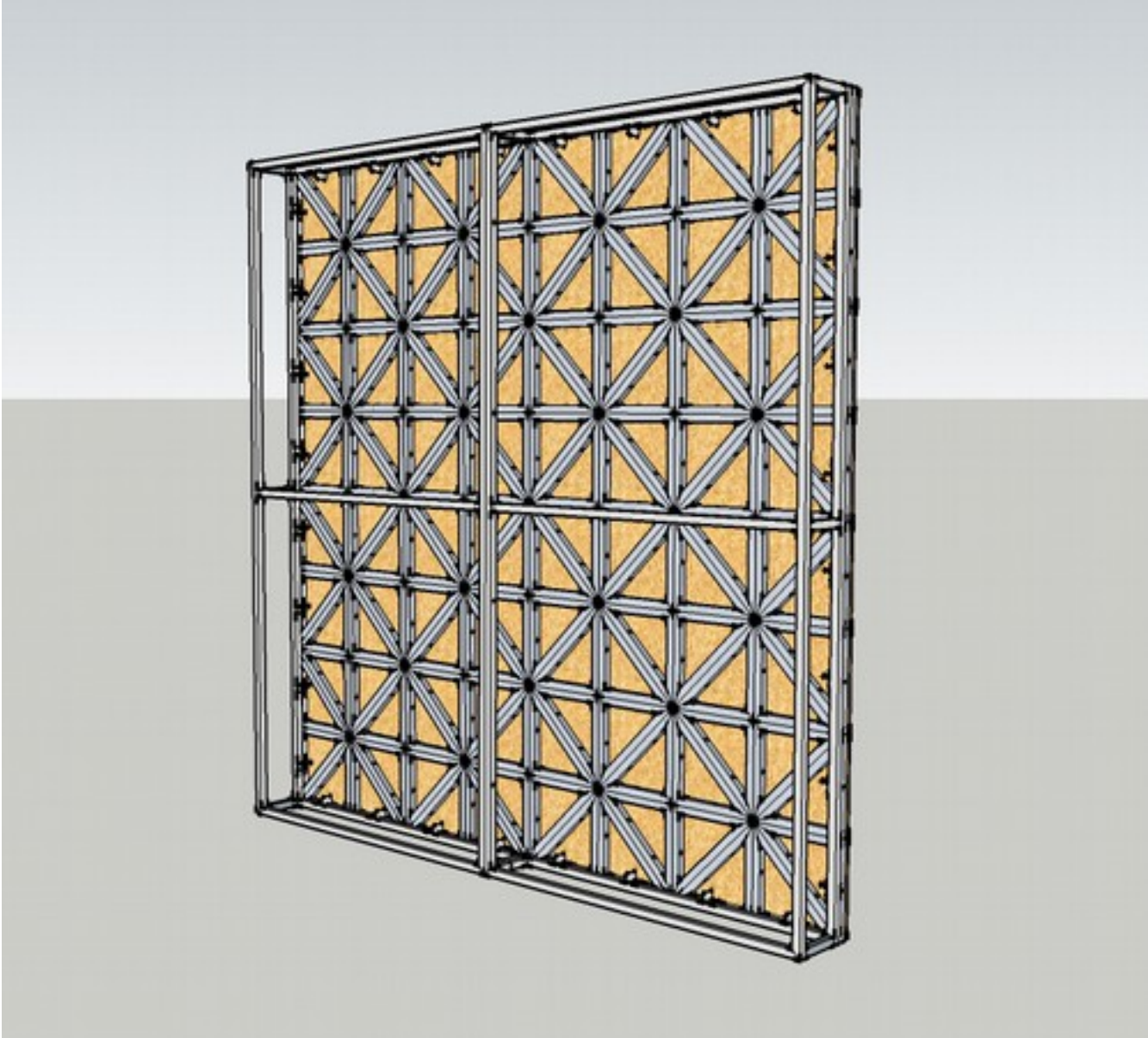

8 FOOT WALL MOUNTING SYSTEM >

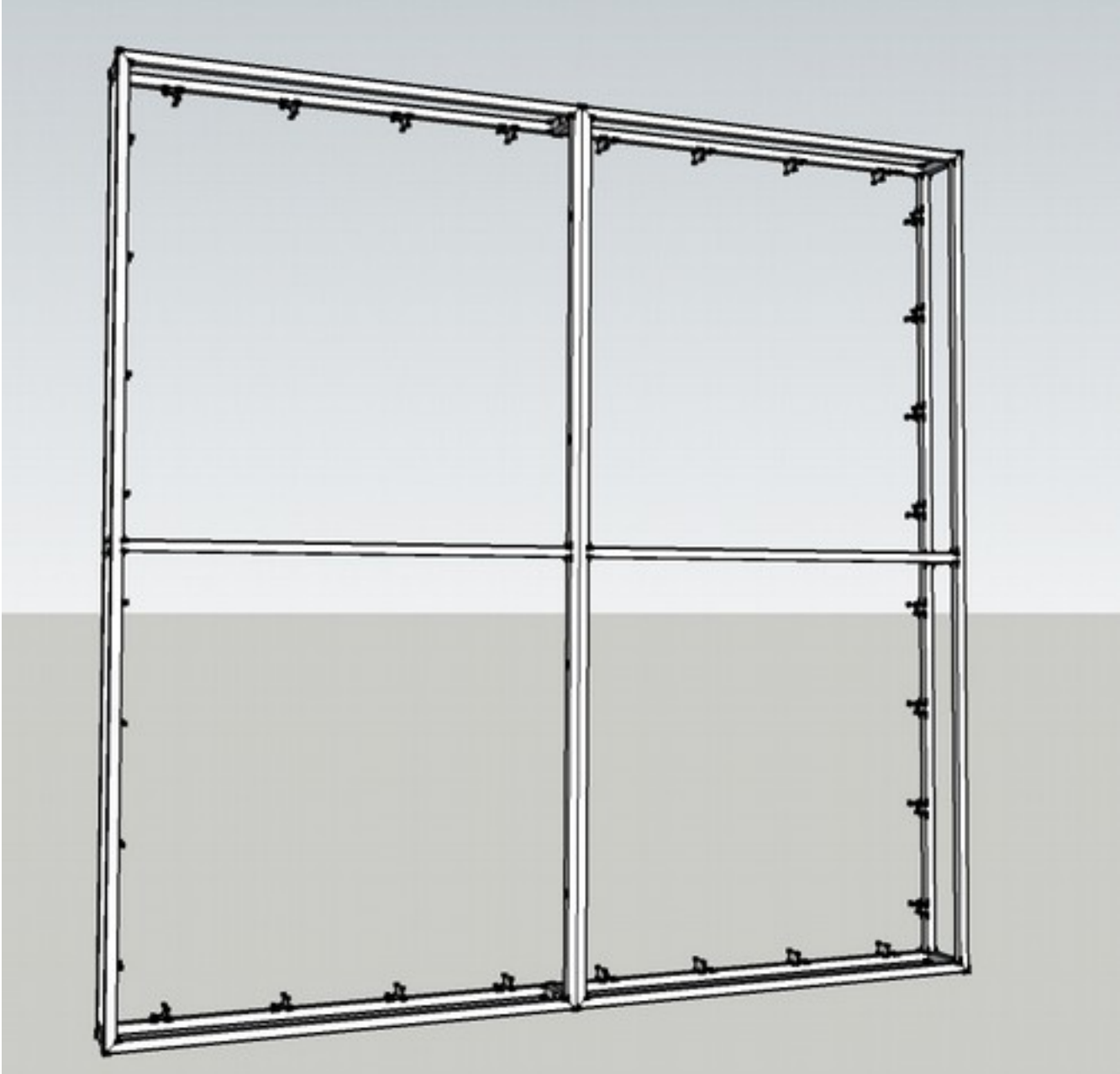

24 INCH CUBE WITH MOUNTING BRACKETS >
(CLOSED)

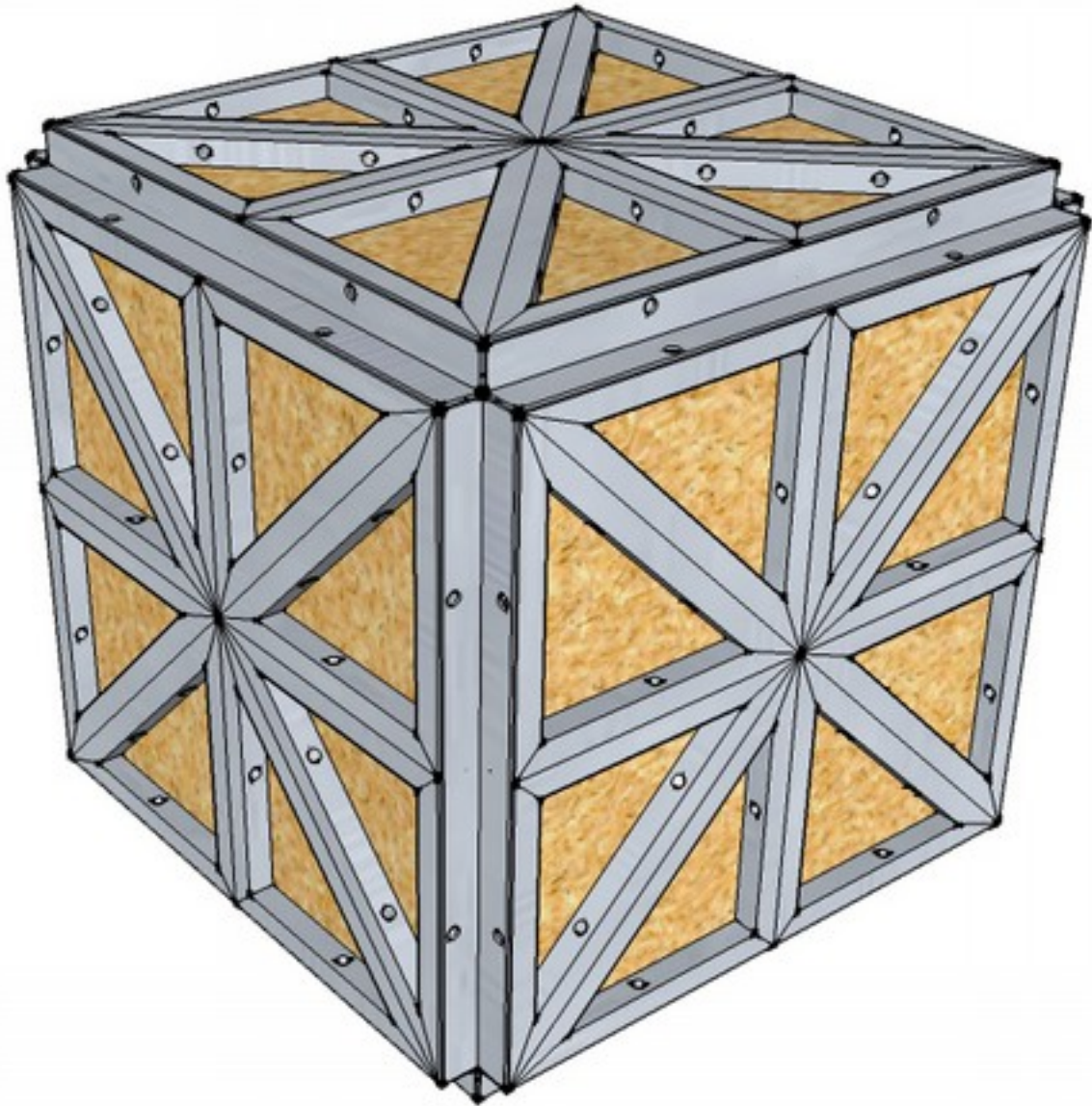

24 INCH CUBE WITHOUT MOUNTING BRACKETS >
(OPEN)

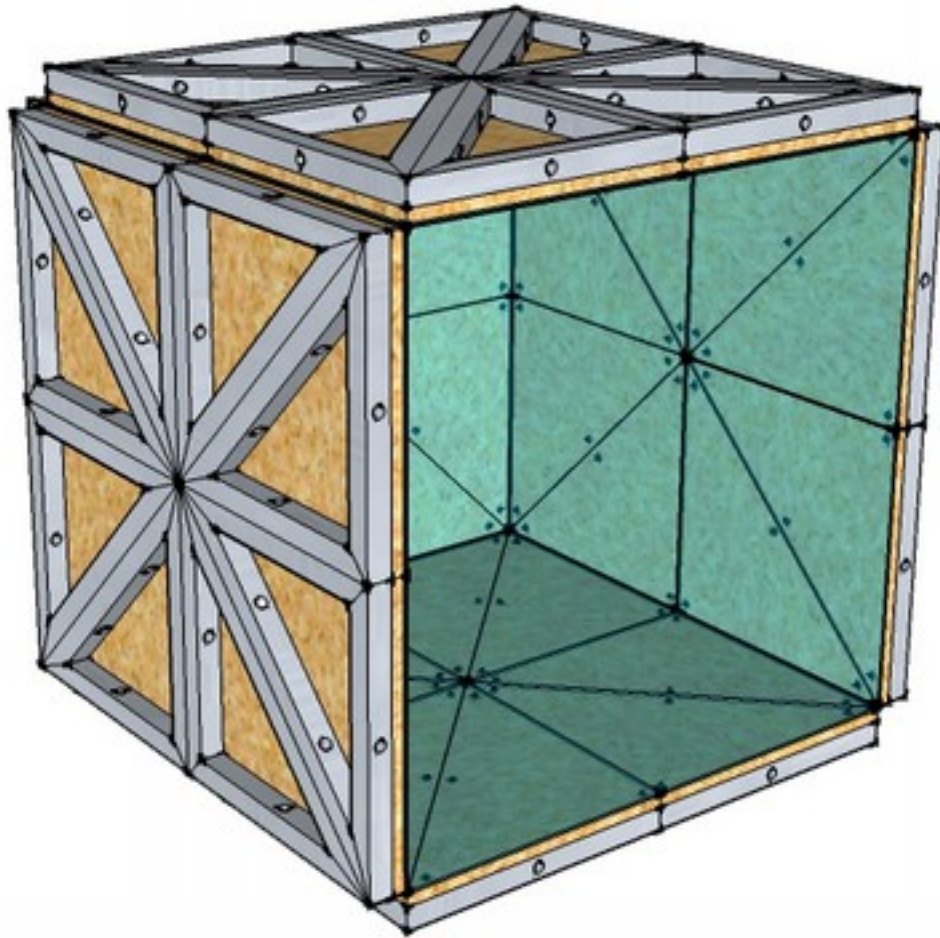

**ALUMINUM FRAME WELDING JIG >
MADE FROM STEEL PLATE AND ANGLE IRON**

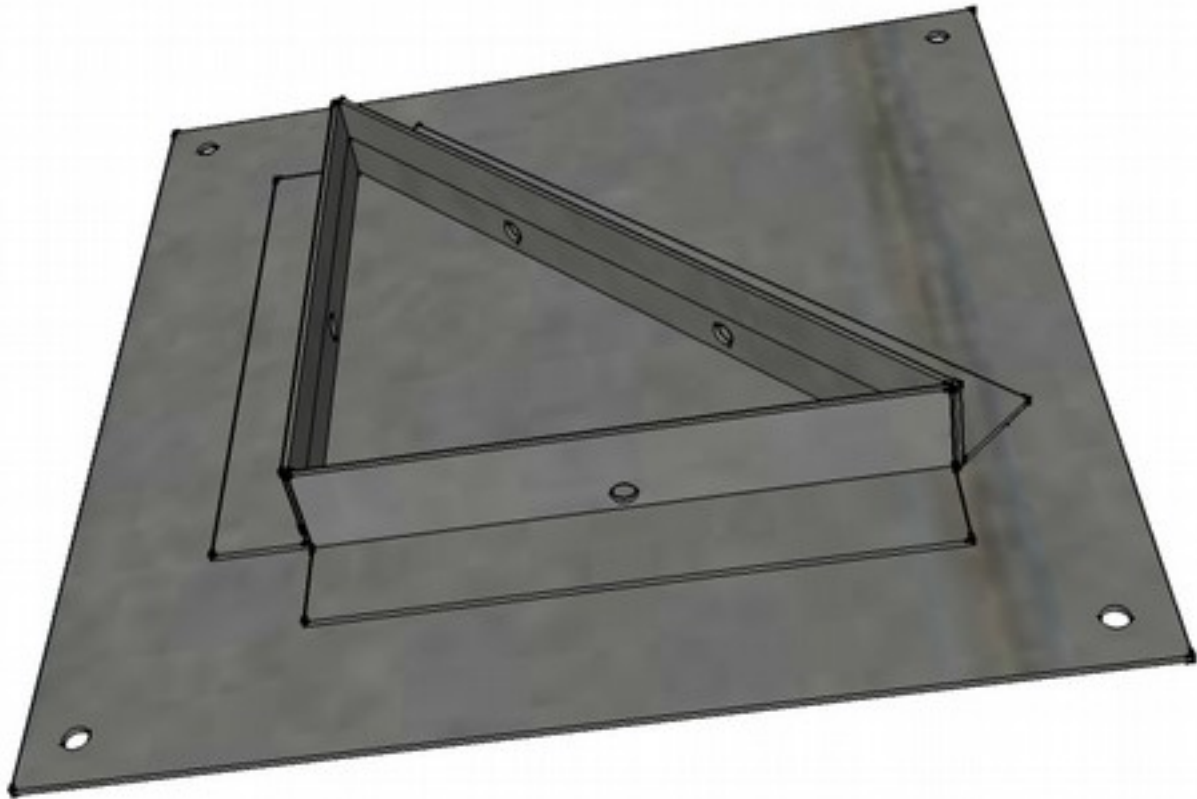

**LIGHT RIGHT TRIANGLE GRID UNITS
(LRTGU) SKETCHES**

INITIAL SKETCH FOR LRTGU >

LRTGU SYSTEM

LIGHT
RIGHT
TRIANGLE
GRID UNIT
SYSTEM

GRIDDED
REPEATABLE
INTEGRATED
DESIGN

- CASE FOR STORAGE?

- SUB-STRUCTURE?



Layered
for extra
strength?

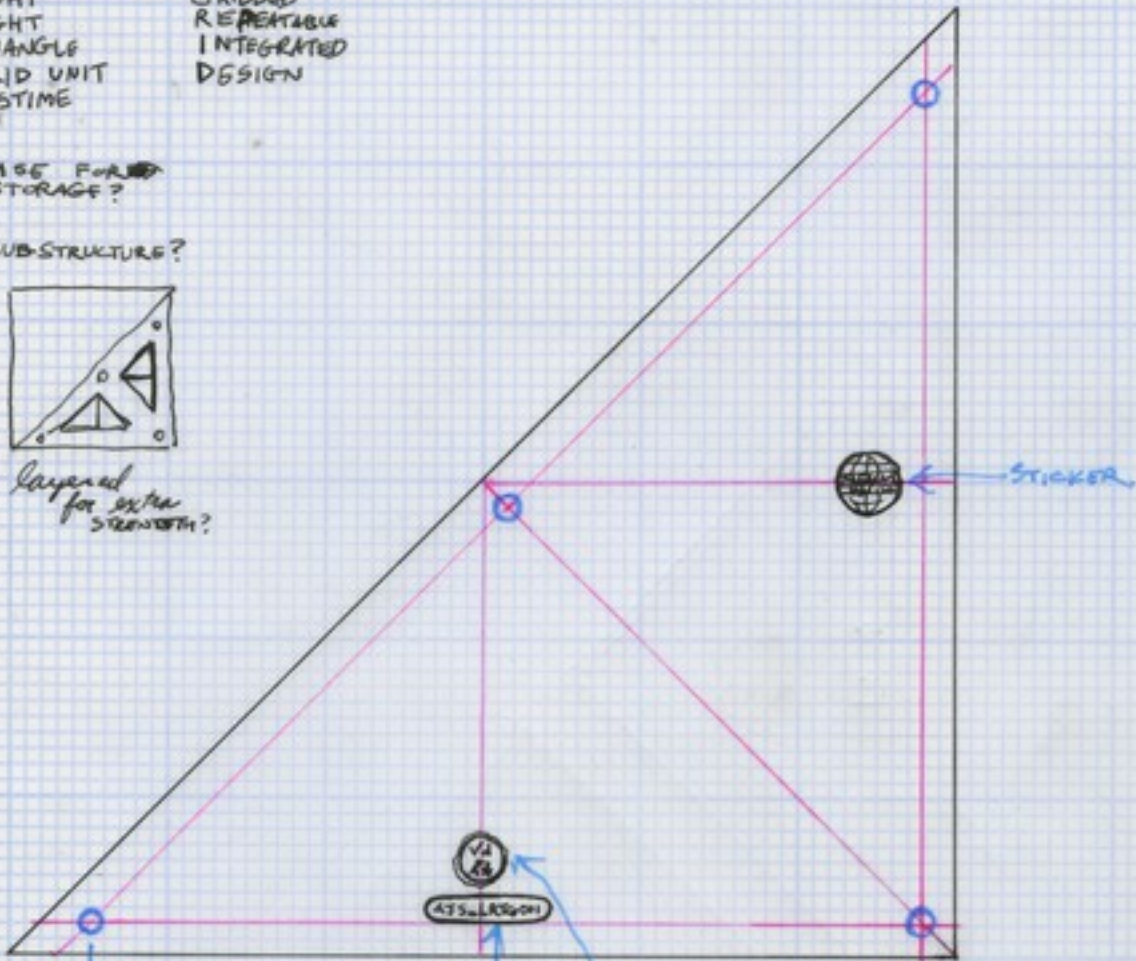

RARE EARTH MAGNETS
EPOXY in place

4 TOTAL

- MOUNTS TO
SCREWS IN WALLS

SKETCH FOR LRTGU STRUCTURAL LAYER >

& STRUCTURE

LIGHT
RIGHT
TRIANGLE
GRID
UNIT

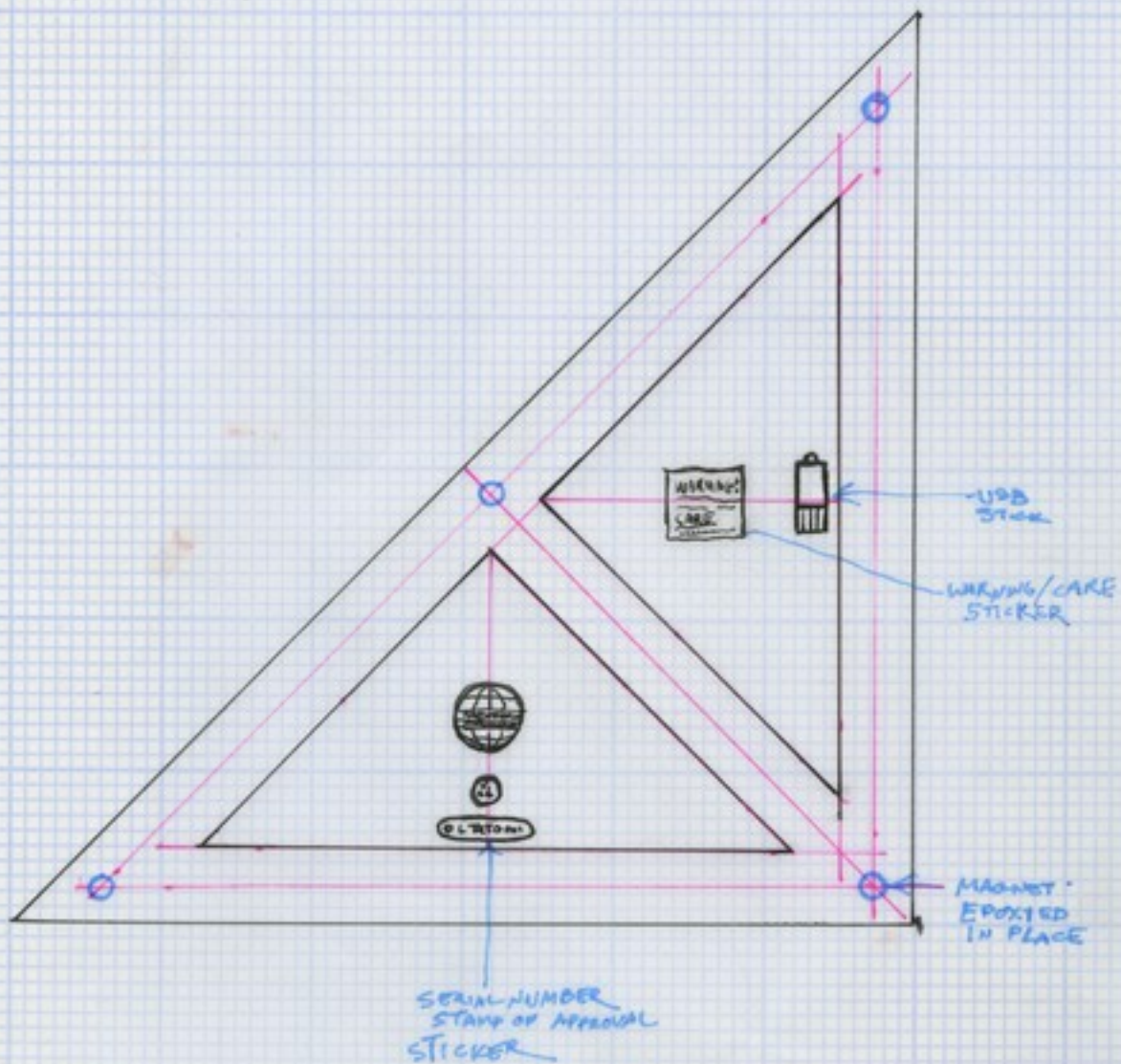

SKETCH FOR LRTGU SAMPLE ARRANGEMENT >

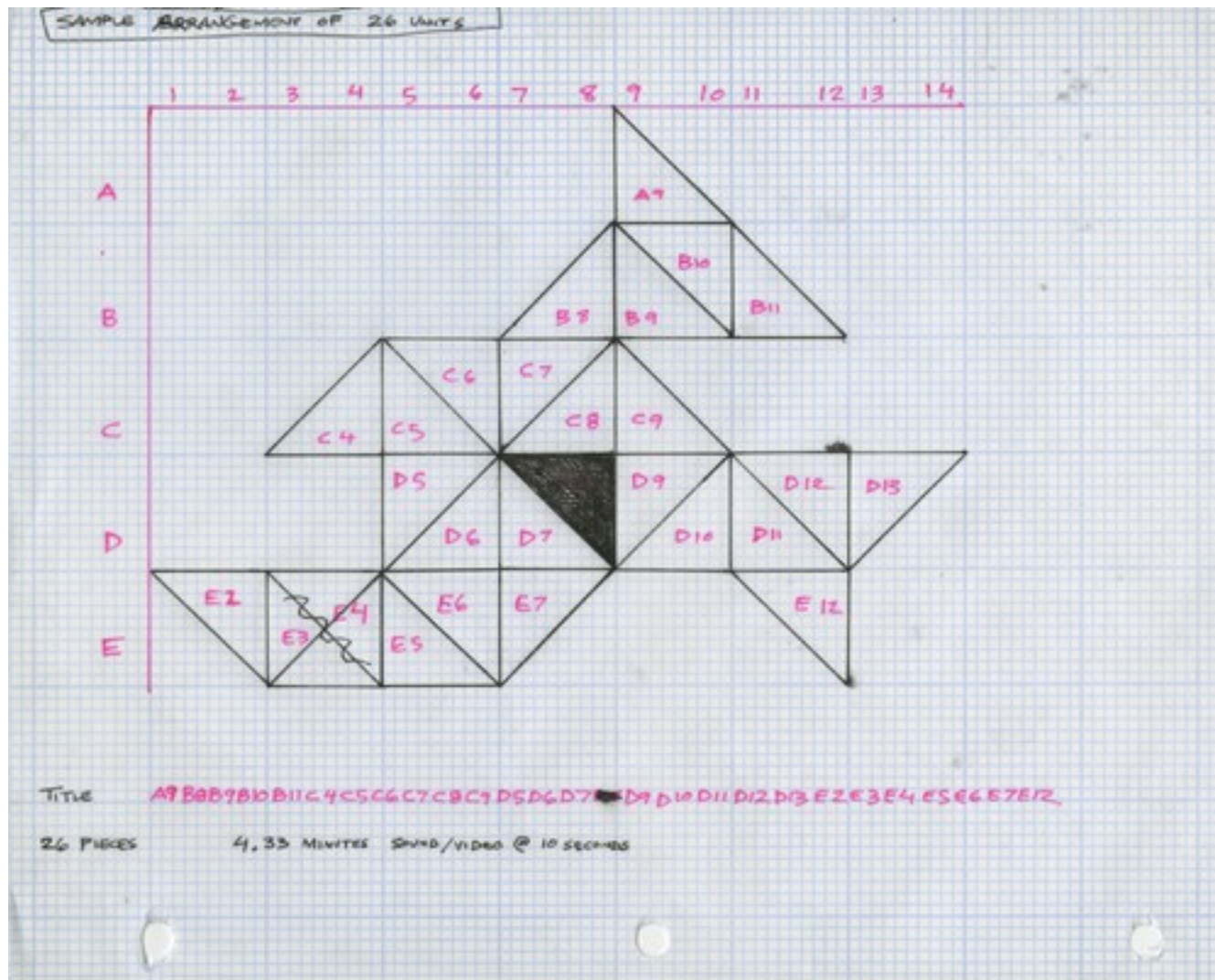

COMPUTER MODELS FOR LRTG UNITS

SKETCHUP MODEL FOR LRTGU >

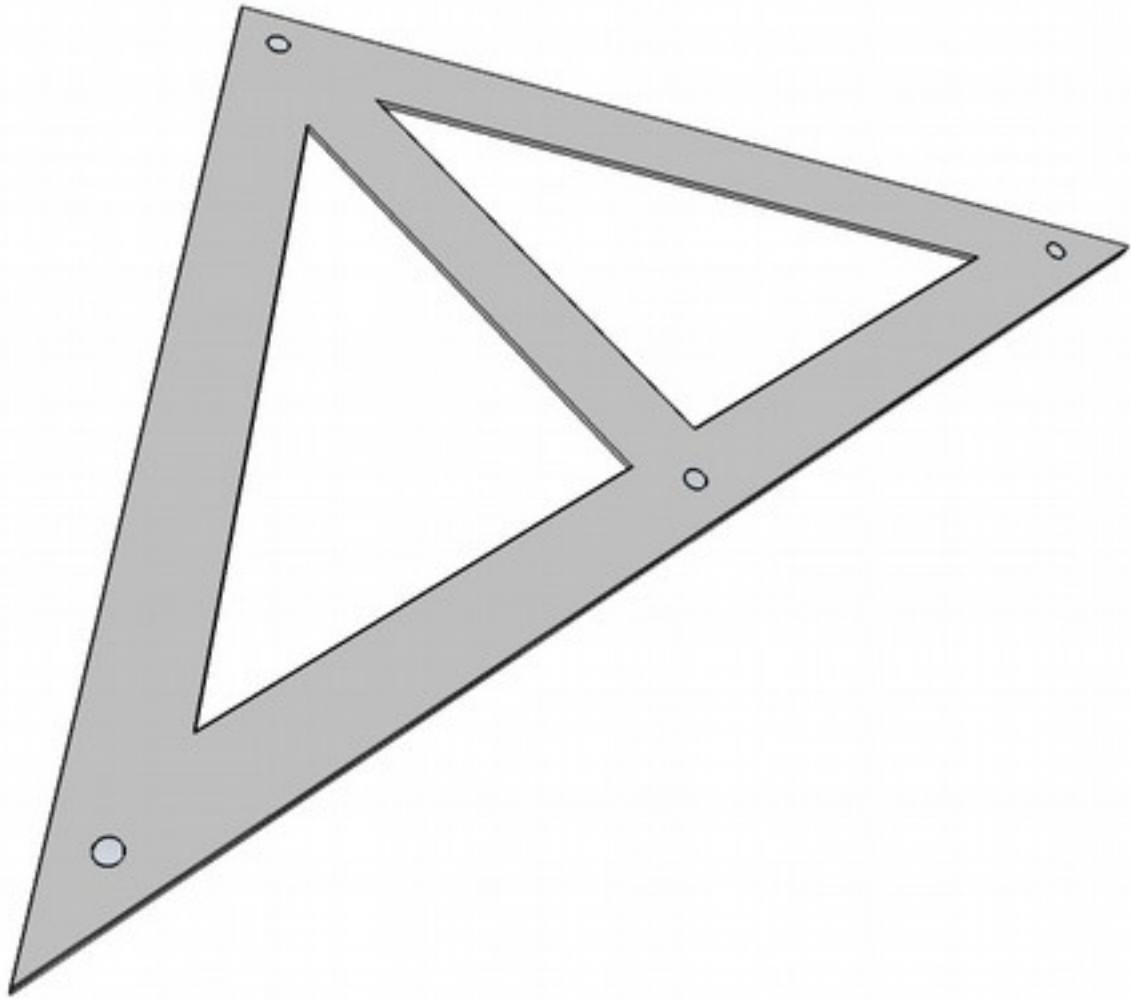

AUTOCAD DRAWING OF LRTGU STRUCTURAL SIDE >

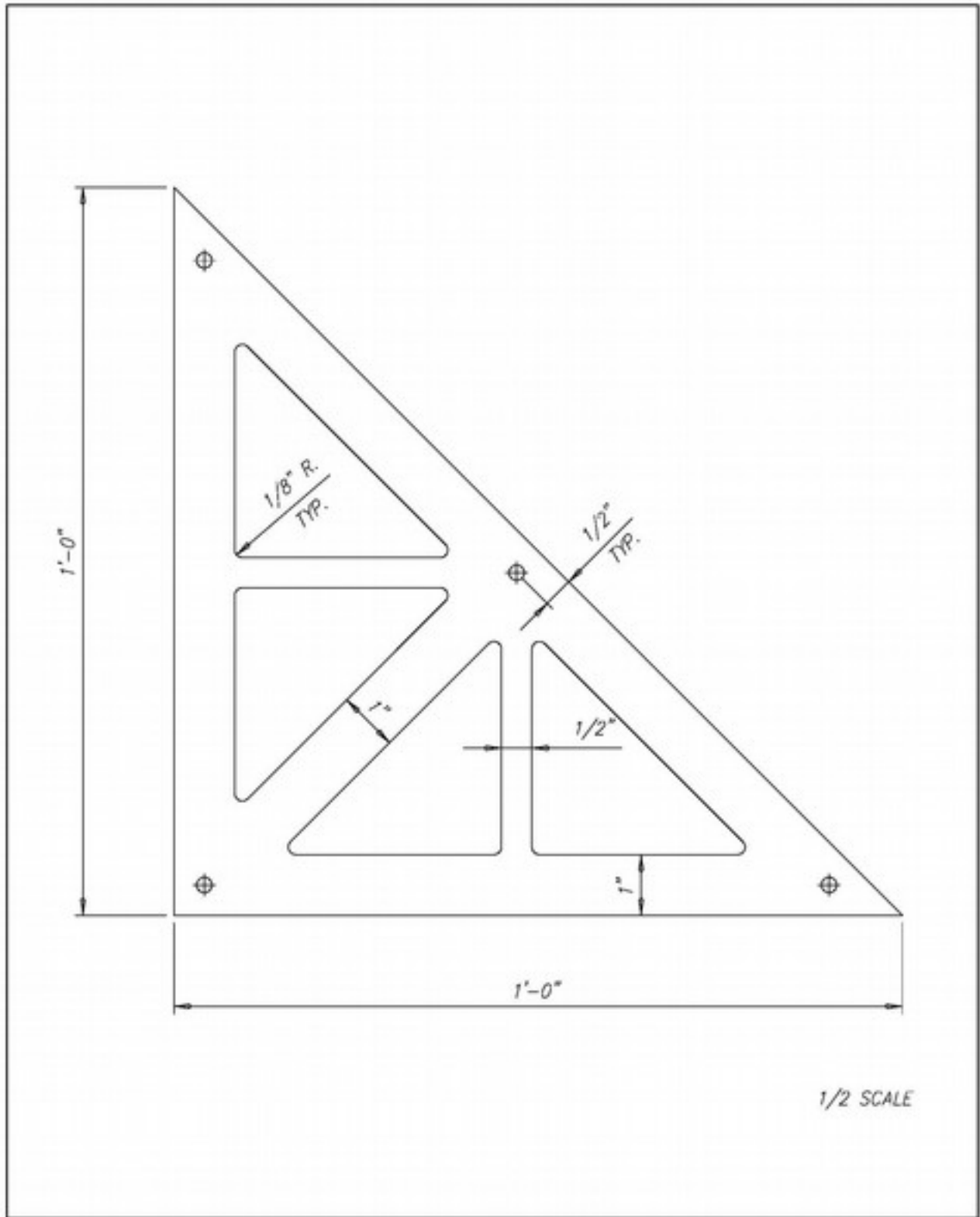

AUTOCAD LAYOUT FOR LRTGU PRODUCTION >

(56) PIECES ON EACH 4' X 8' SHEET SCALE: 1 = 12

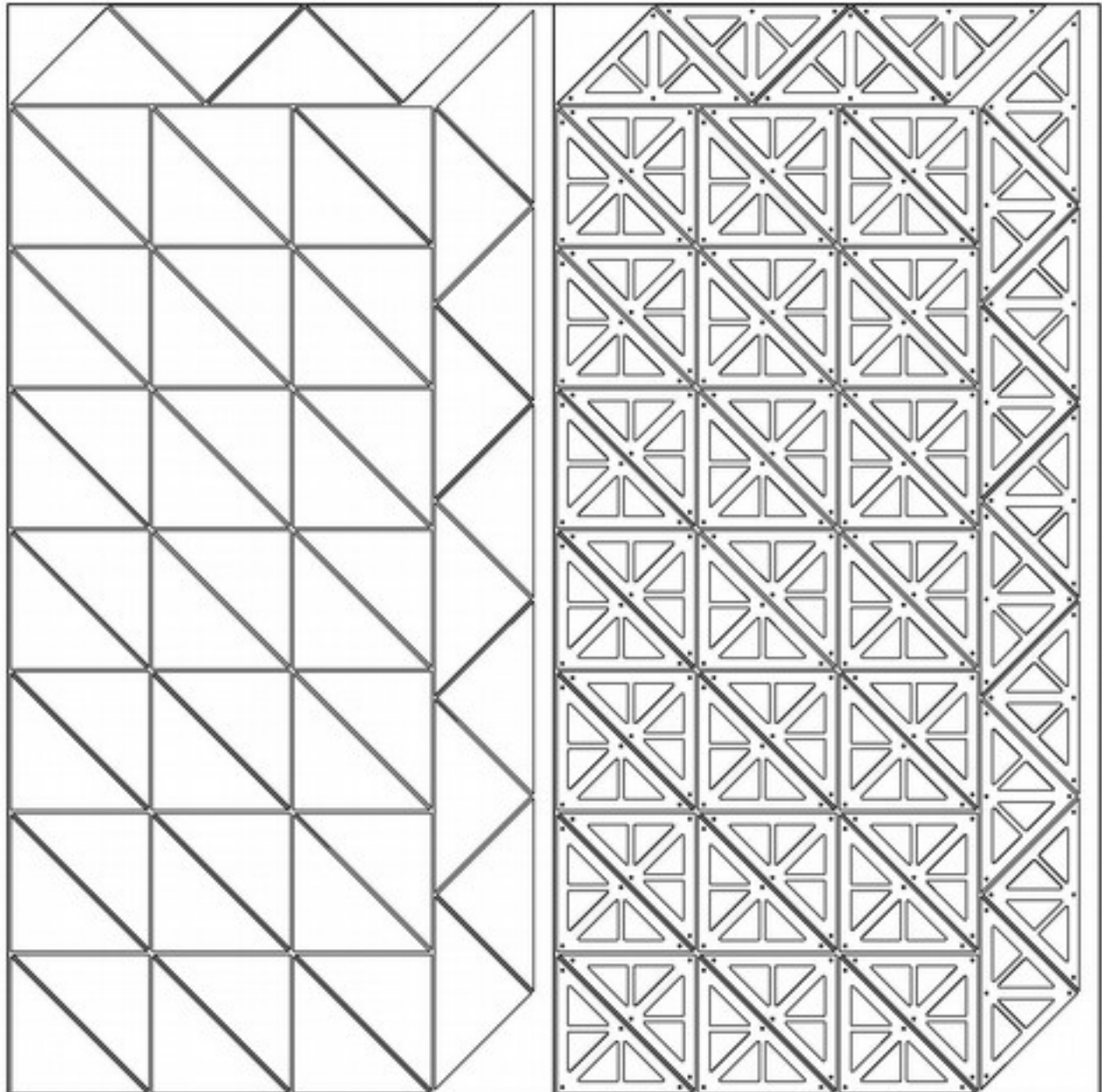

**LIGHT RIGHT TRIANGLE GRID UNIT
(LRTGU) PROTOTYPE (SINTRA©)**

HAND CUT VERSION ONE >

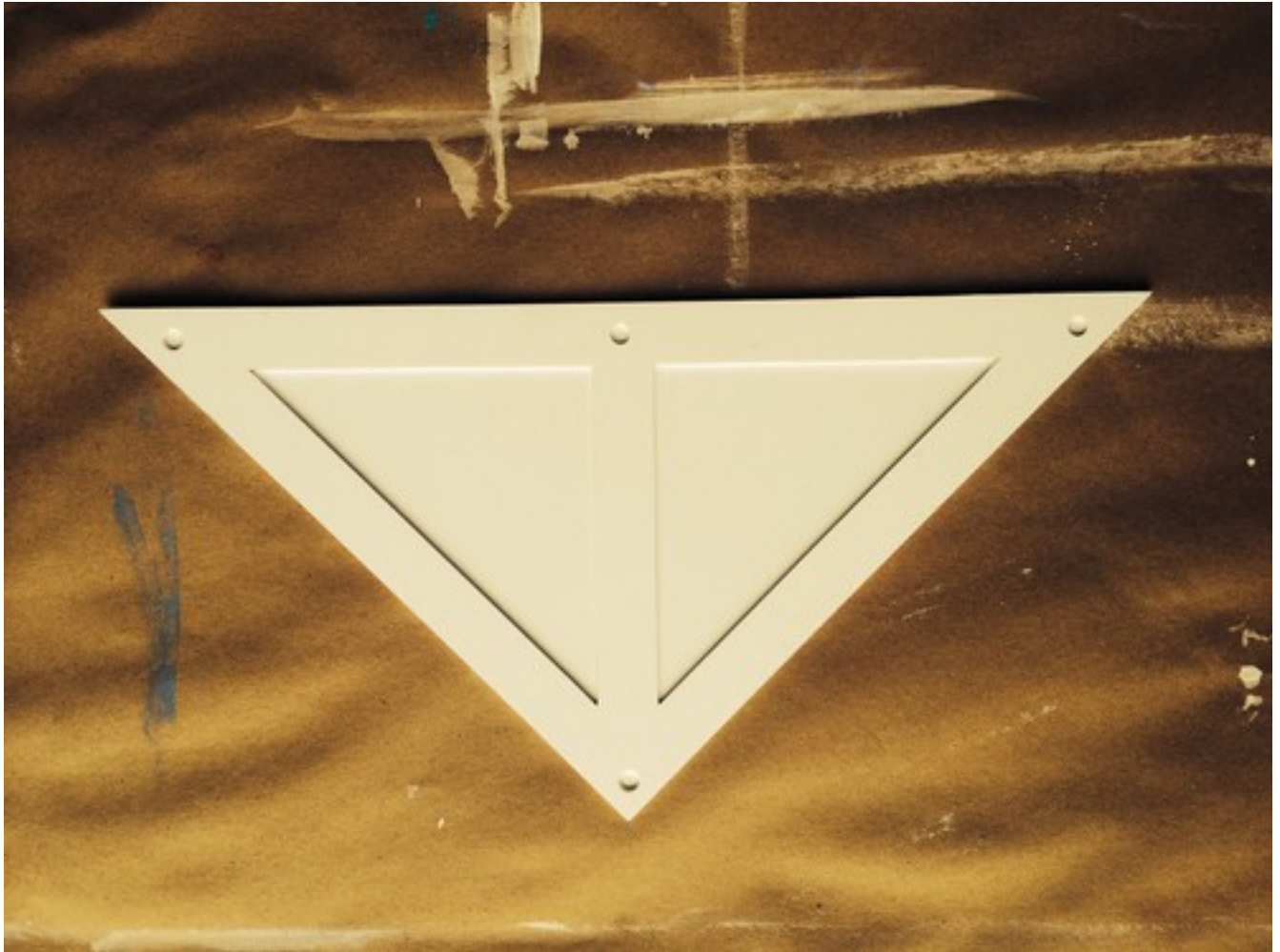

HAND CUT VERSION TWO >

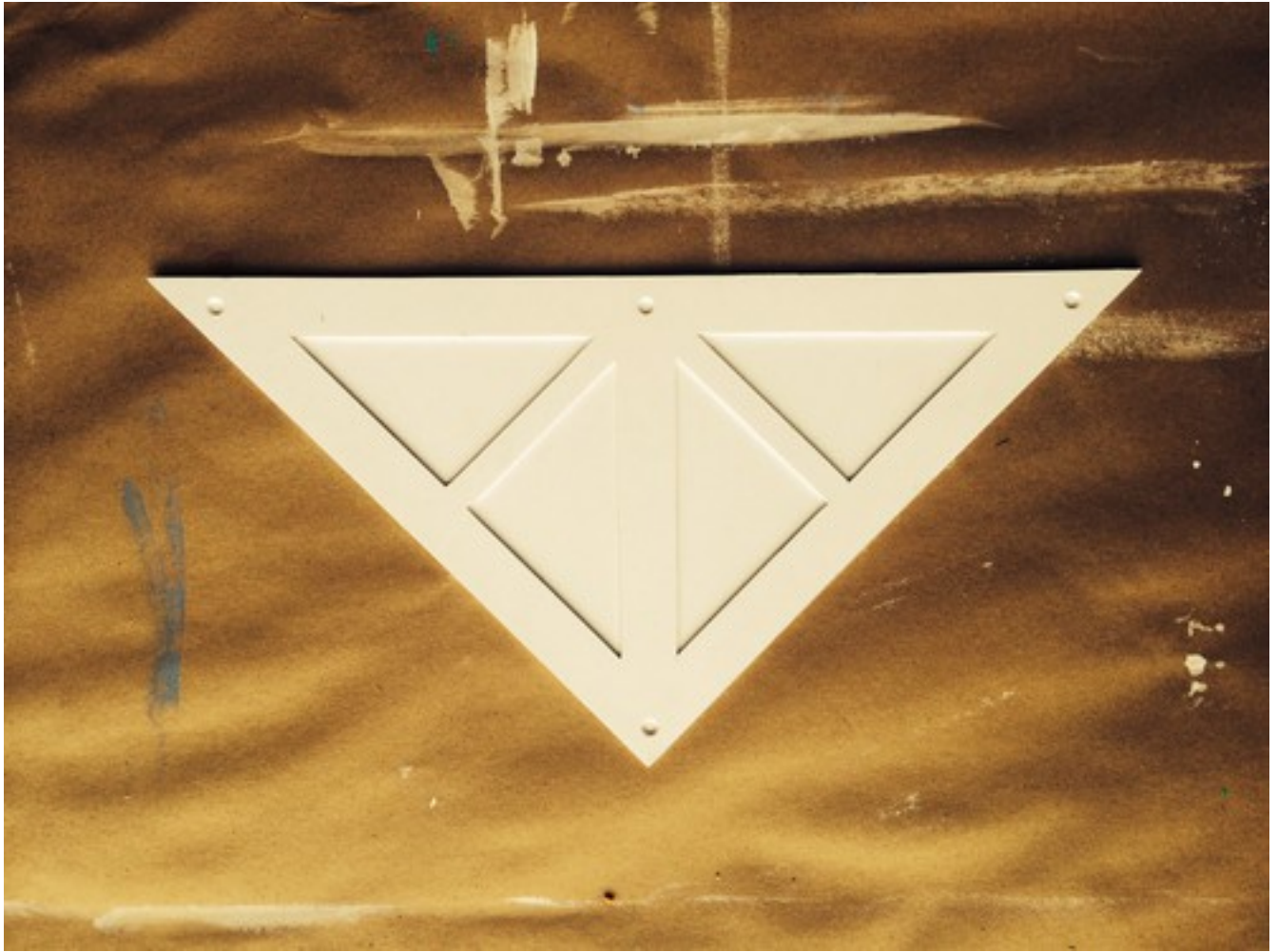

FOUR UNITS IN SQUARE FORMAT >

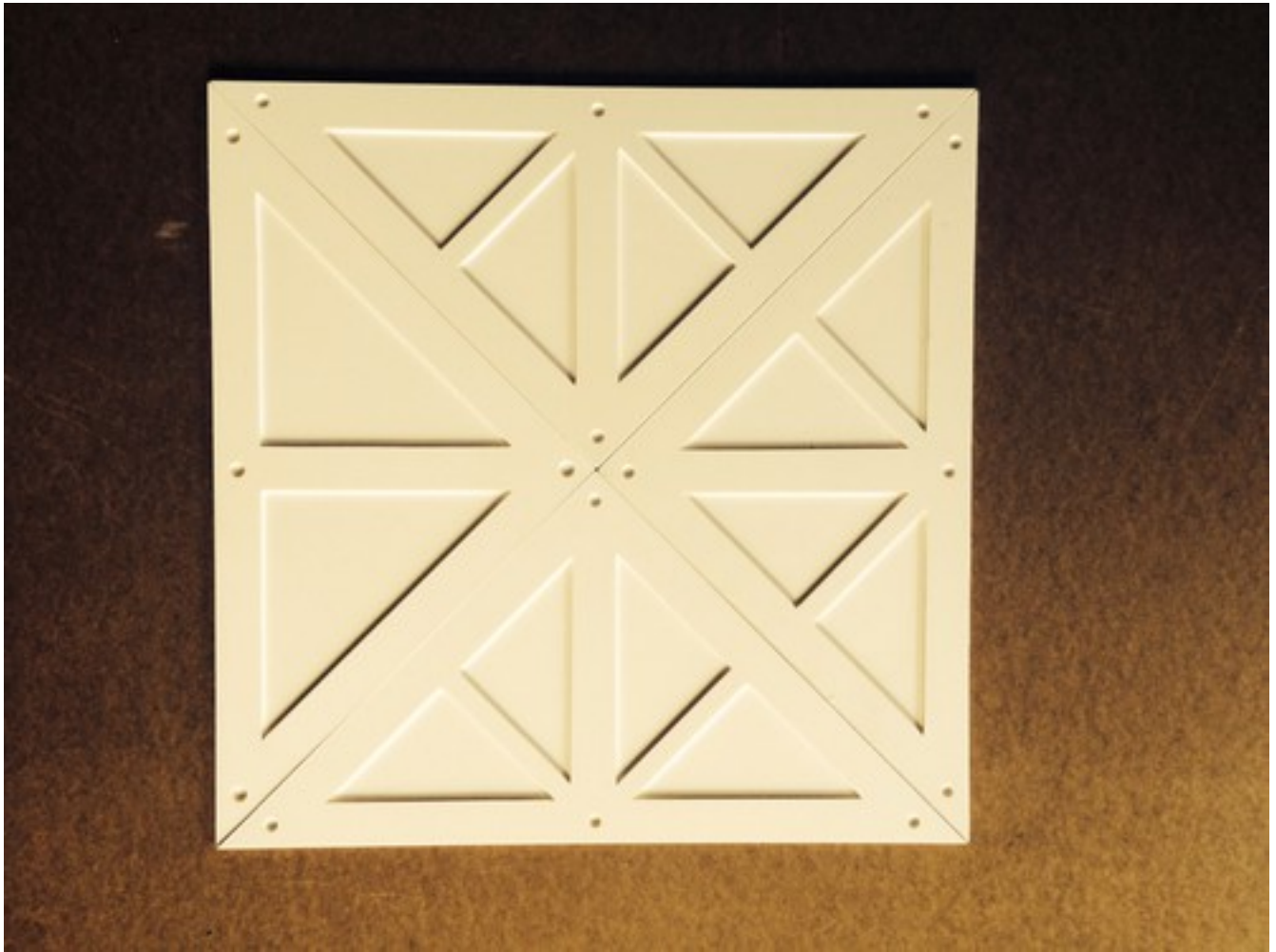

PRODUCTION UNITS AFTER MANUFACTURING >



CUTIE JIG® FOR ASSEMBLING PROCESS >



SIX UNITS AFTER ASSEMBLING >

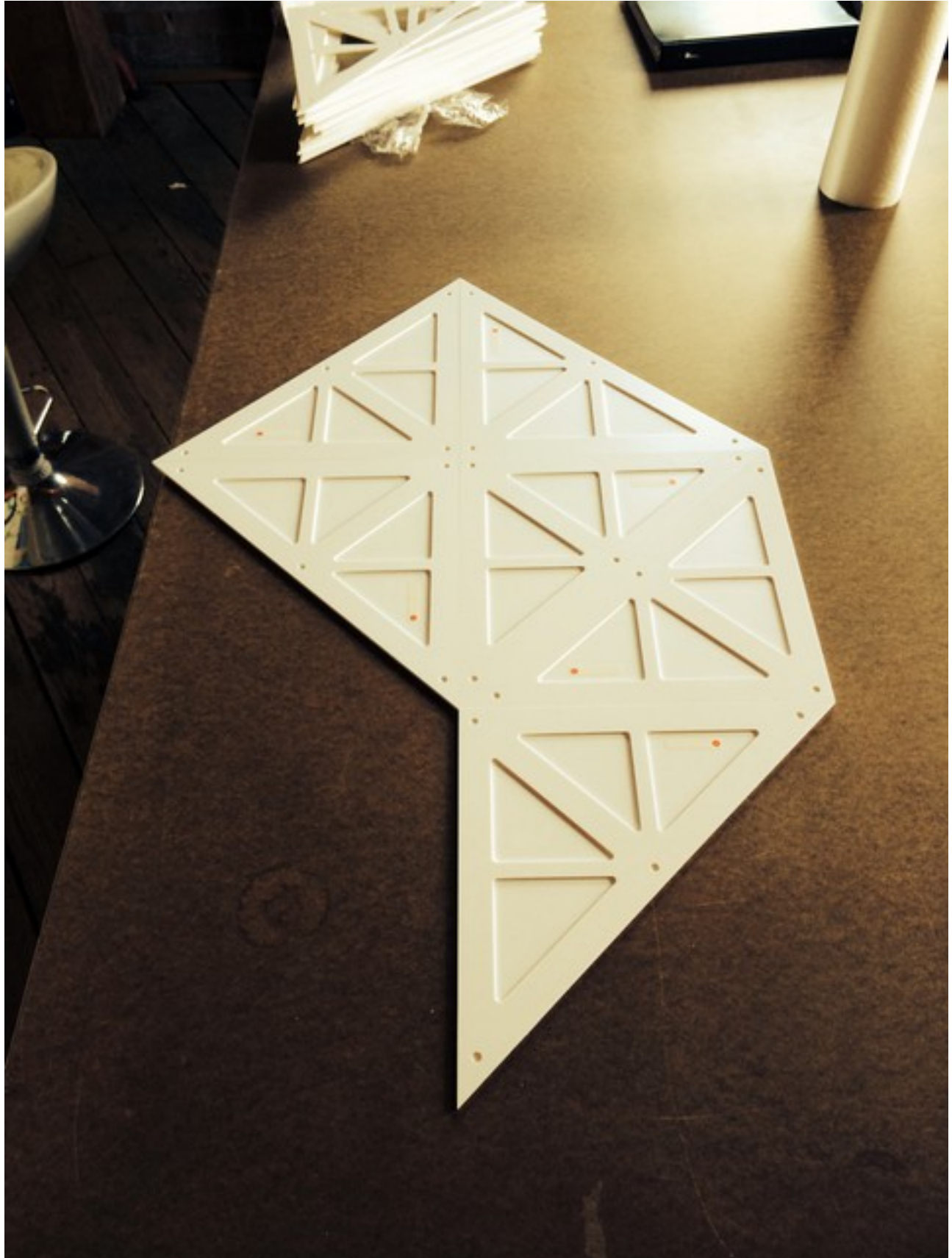

FOUR UNITS DURING PAINTING PROCESS >



A Meatchunk Cutie Book

MECB_001

©2013-14 MEATCHUNK ENTERPRISES, INC.

www.andrewjacobschell.com